



Spółka Restrukturyzacji Kopalń S.A.

INVESTMENT OFFER

Ground real property at street Baczyńskiego in Sosnowiec – Milowice – the Silesia province.

The real property is situated at ground road, which is joined two streets: Baczyńskiego and Szybikowa. The street Szybikowa belongs to Czeladź.

The Ground real property is situated in the North away from new building the Under Zone Sosnowieco-Dąbrowskiej the Special Economical Zone of Katowice.



Sosnowiec is situated in Silesia Highland and in part of the Basin Dąbrowskie. Taking into geology consideration Silesia is located in Upper Silesia Coal Basin, which there are incorporated Industrial Region of Upper Silesia and the Coal Region of Rybnik.

Sosnowiec border with: Czeladź, Będzin, Dąbrowa Górnicza, Sławków, Jaworzno, Mysłowice and Katowice.

The Expressway A4 is located near town Sosnowiec. Moreover Sosnowiec has two roads: S1, S86 and two local roads number: 78, 94.

Sosnowiec is the biggest economic center in Poland. The industrial town (industrial mining and heavy) modified in business, service and modyficatory center, for last years.



© Publishing house Witanski - Katowice

GROUND DATE

Owner –

The Tresury of Poland

Perpetual usufructuary -

Spółka Restrukturyzacji Kopalń S.A.
ul. Strzelców Bytomskich 207; 41-914 Bytom
Tel.: +48 (prefix) 32/35 - 13 - 300, 32/35 - 13 - 301
Fax: +48 (prefix) 32/35-13-309; 32/35-13-310;
www.srk.com.pl

Use according to the development plan -

Industrial area, magazine area (Complex I under zone Sosnowiecko-Dąbrowskiej Specjal Economical Zone of Katowice).

Actual way of development -

The area is flat and verdant (geen low).

Informtions about neighbouring areas –

In neighbourhood are industrial bilut-up areas, which there are in the Economical Zone of Sosnowiec and farm barrens.

Existing utilities –

The area don't have utilities.

Transport accesibility –

There is possibility to drive ground roads from street Baczyńskiego. Connection with express roads S1, S86 (Katowice-Warszawa) and with roads number 78, 94.

Suggested form of disposal –

The sale of the perpetual exploitation till 2089 by the public tender. Preferred sale of the whole real property.

Contact person –

The Specialist for Projects and Marketing,
Iwona Krol
tel.: +48 (prefix) 32/35-13-366;
e-mail.: ikrol@srk.com.pl

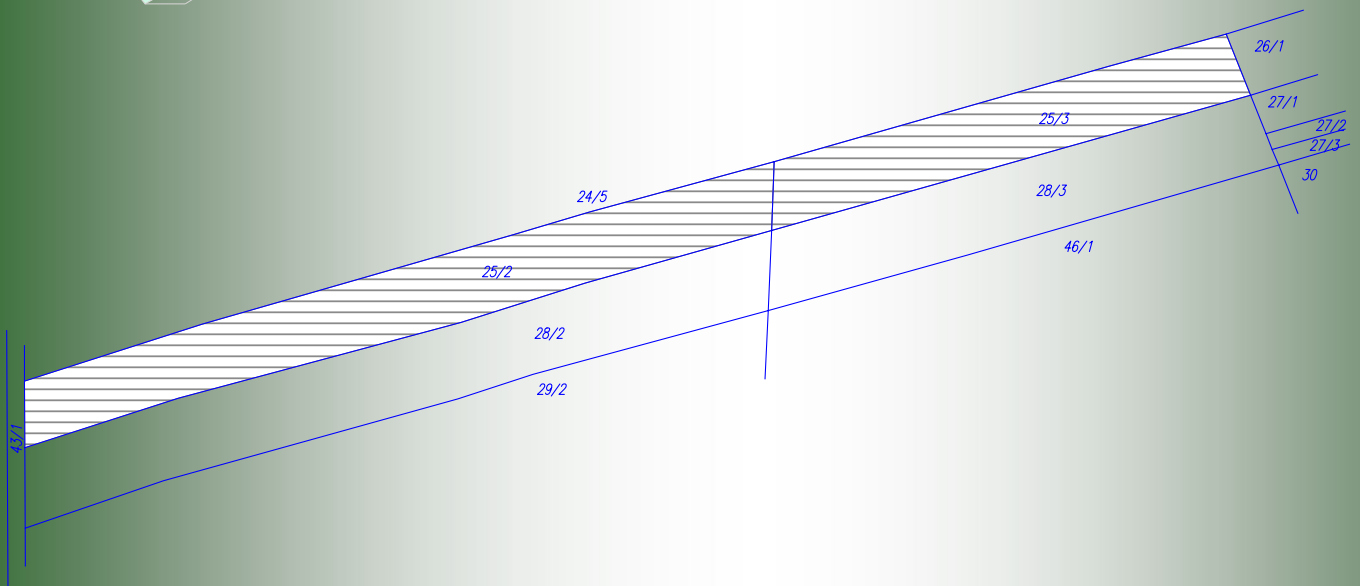

RECORD MAP

TOTAL AREA 0,5 ha (5070 m²)